

RV+

The RV+ standard piston valve technology is applicable to monotube and double-tube dampers. The basic rebound clamped disc valve offers a cost-efficient design that is available in all standard sizes.

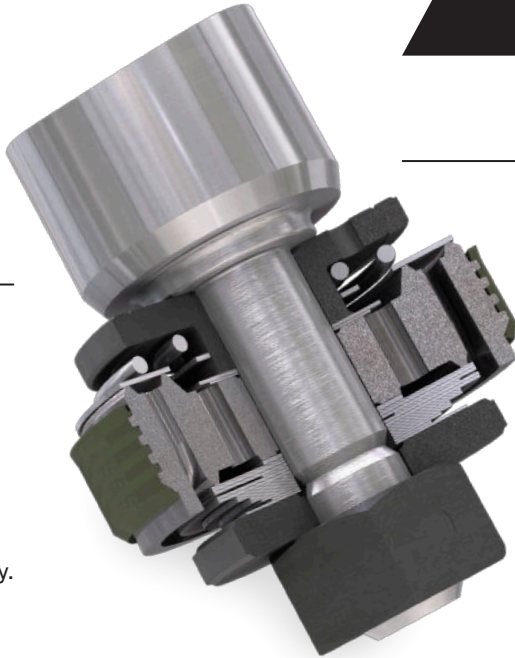

Enhanced comfort performance and temperature stability.

Common applications include those with high rebound to compression and damping ratios. Available for all vehicle segments.

1. Enhanced comfort performance and temperature stability.
2. Common applications include those with high rebound to compression and damping ratios. Available for all vehicle segments.

